

Vacuum Circuit Breaker



12/24kV
VECTOR series
Vacuum Circuit Breaker
VMS series Metal-clad Switchgear

LKE
Medium
Voltage
Systems



FM 73638

12/24kV VECTOR VCB

■ Features of the VECTOR Vacuum Circuit Breaker:

The **VECTOR** is a cassette-type (withdrawable) 12/24kV Vacuum Circuit Breaker designed for the **VMS** metal-clad switchgear, featuring compact dimensions of the circuit breaker and switchboard panels.

The **VECTOR** VCB has nominal current ratings of up to 2000A, with a maximum breaking capacity of 31.5 kA, and short-time current ratings of up to 31.5 kA / 4 sec.

Whereas the **VECTOR-S** is a spring-mechanism driven VCB, the **VECTOR-M** is driven by a low-energy single-coil permanent-magnet actuator system capable of more than 50,000 mechanical operations.

The **Vector-M** is a low maintenance circuit breaker. The vacuum interrupters are maintenance-free with a minimum lifetime of 20 years. Maintenance of the operating mechanism is only required after 10 years or 25,000 operations. After 40,000 switching operations a general inspection by the manufacturer is recommended.

■ VECTOR VCB compliance with the following standards:

IEC 298, IEC 185 , IEC 282,

IEC 529, IEC 186 ,IEC 56,

IEC 129, DL 404

■ Ambient conditions

- Ambient temperature: -25 °C to +40 °C.
- Relative humidity: daily average of less than 95% and monthly average of less than 90%.
- Height above sea level of less than 1000 m.
- Earthquake intensity less than 8 degree.
- Environment: no frequent violent vibration.



VECTOR24-S32



VECTOR12-M32

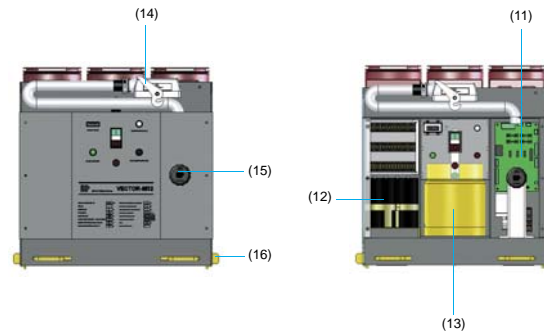
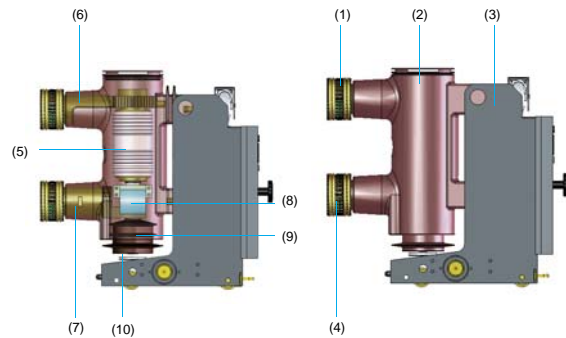

Section view of VECTOR

- | | |
|--|---|
| (1)--Top terminals with lotus contacts | (9)-- Insulated push rod |
| (2)--Interrupter housing of epoxy resin | (10)--Contact load spring |
| (3)--Truck | (11)--Actuator controller |
| (4)--Lower terminals with lotus contacts | (12)--Capacitor banks |
| (5)--Vacuum interrupter | (13)--Permanent magnet actuator |
| (6)--Top copper conductor | (14)--Auxiliary terminal connection block |
| (7)--Bottom copper conductor | (15)--Manual trip button |
| (8)--Flexible copper connection. | (16)--Position interlock |

For ratings of current 1600A & above sliding contacts are used instead.

Technical parameters

Electrical Characteristics	Unit	VECTOR12-M32	VECTOR12-S20-S32	VECTOR24-S20-S32
Rated Voltage	kV	12	12	24
Rated current	A	2000	1250	1250
Rated frequency	Hz	50/60	50/60	50/60
Rated power-frequency withstand voltage	kV	28/32	28/32	50/60
Rated Lighting impulse withstand voltage	kV	75/85	75/85	125/145
Rated short-circuit breaking current	kA	31.5	20, 25, 31.5	20, 25, 31.5
Rated short-time withstand current	kA/s	31.5/4	20/4, 25/4, 31.5/4	20/4, 25/4, 31.5/4
Rated peak withstand current	kA	80	80	80
Rated short-circuit making current	kV	80	80	80
Mechanical endurance	cycles	20000	20000	30000
Rated Operating sequence		O-0.3s-CO-180s-CO		
Mass	kg	170	120	130

The VECTOR as the following general dimensions

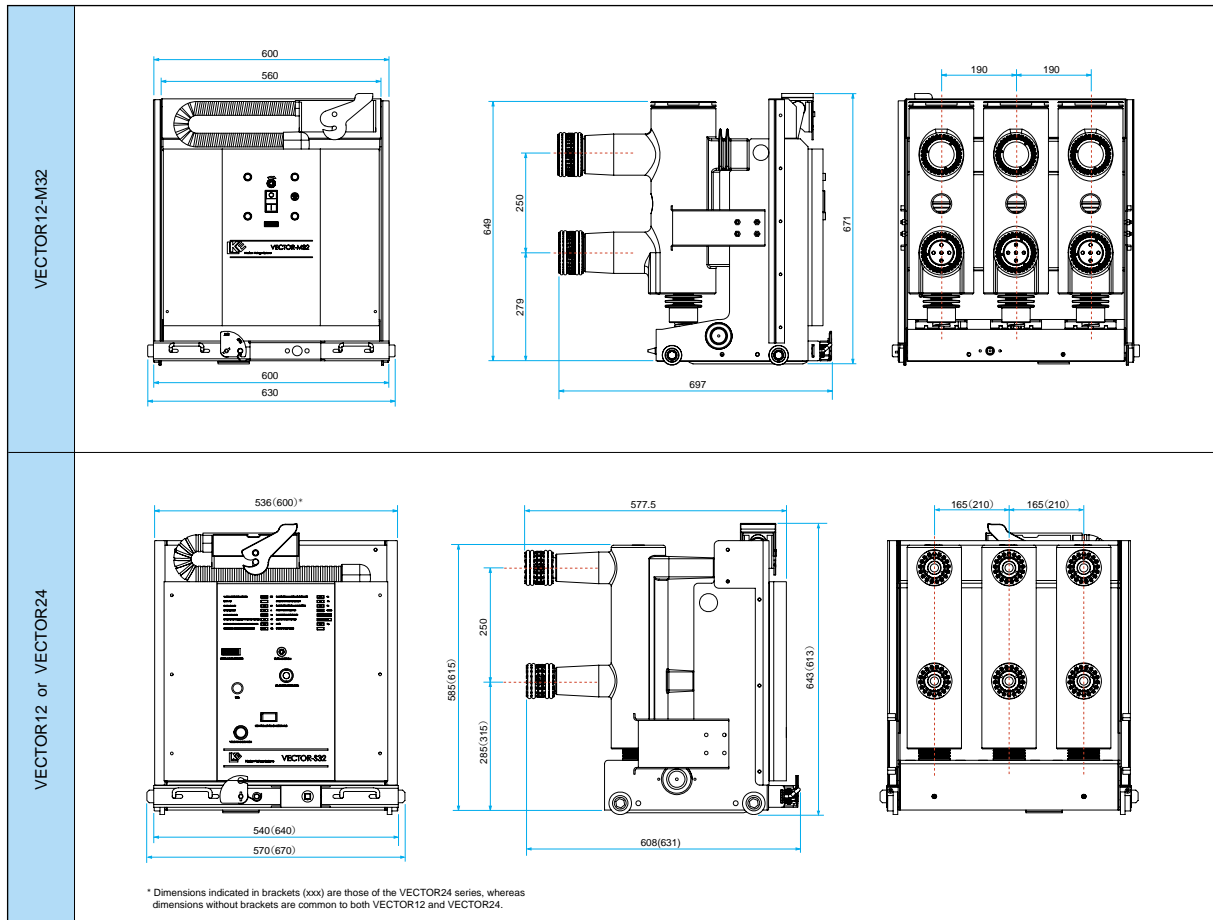

VMS Metal-clad switchgear

The type **VMS** metal-clad switchgear is designed for installation in distribution substations, transformer substations, electric power stations and industrial companies.

■ Features

- Air-insulated switchgear panels, metal-enclosed, metal-clad, with a single busbar system.
- Compact dimensioning arising from the compactness of the Vector-M/S and the combination of the terminal box, the current transformers and the voltage indicators into a single component bloc.
- The cable connection compartment is readily accessible through a separate door.
- Ease of operation on closed front section.
- High staff safety through closing of the busbar compartment cladding even in service position.
- Reliability through effective mechanical interlocking system.
- Modular construction allows high flexibility and adaptability.
- Easy access to the various switching devices for routine tests even with maximum complements.

■ The design of the VMS

- The basic frame and supports for mounting the incorporated devices are designed as a compound construction made of welded and bolted parts.
- Reinforced H-frame provides the necessary robustness to withstand internal arcing.
- The reinforced sheet-steel door is provided with a four-point centrally controlled locking system.
- The withdrawable chassis is moved by means of a manual crank into the service and disconnected positions.
- The circuit breaker truck is placed upon the chassis in the service and disconnected positions. For removing the circuit breaker truck, it is slid from the chassis onto a transport trolley and locked onto the trolley for transportation.
- The transport trolley and thus the circuit breaker, may be moved without any other mechanical aid.

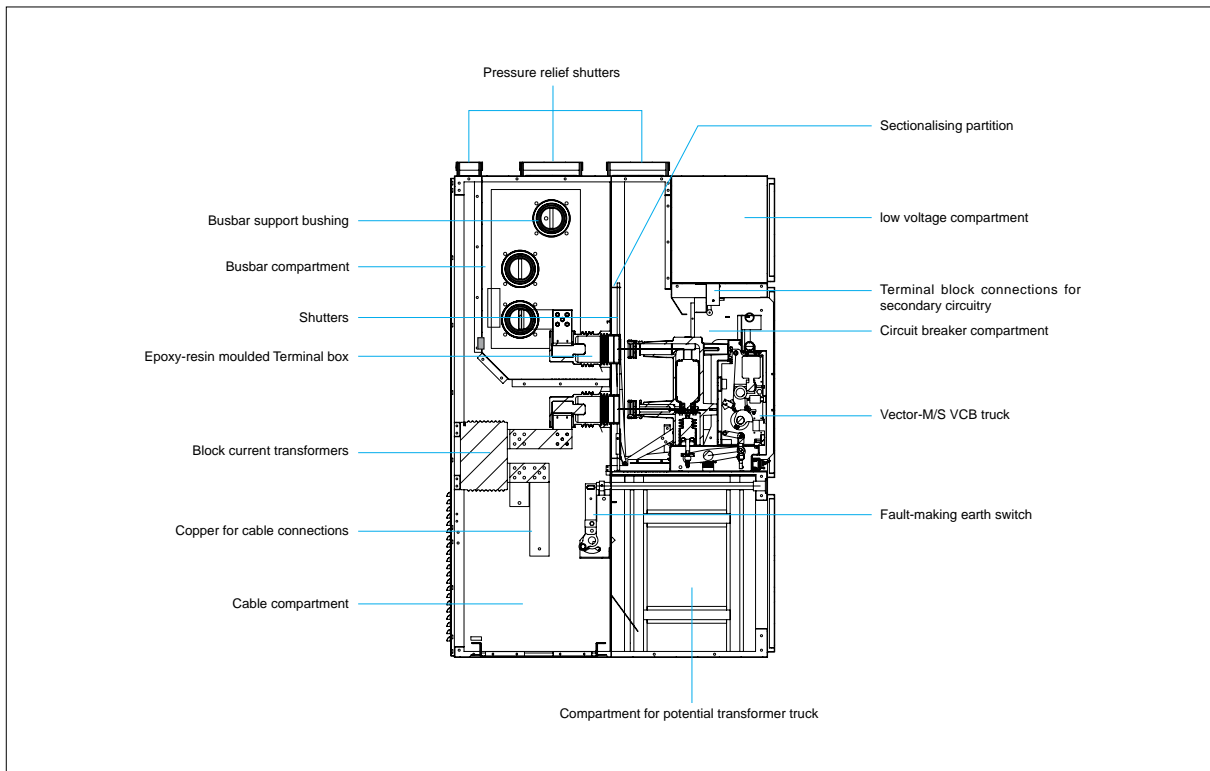

Switchgear panel dimensions

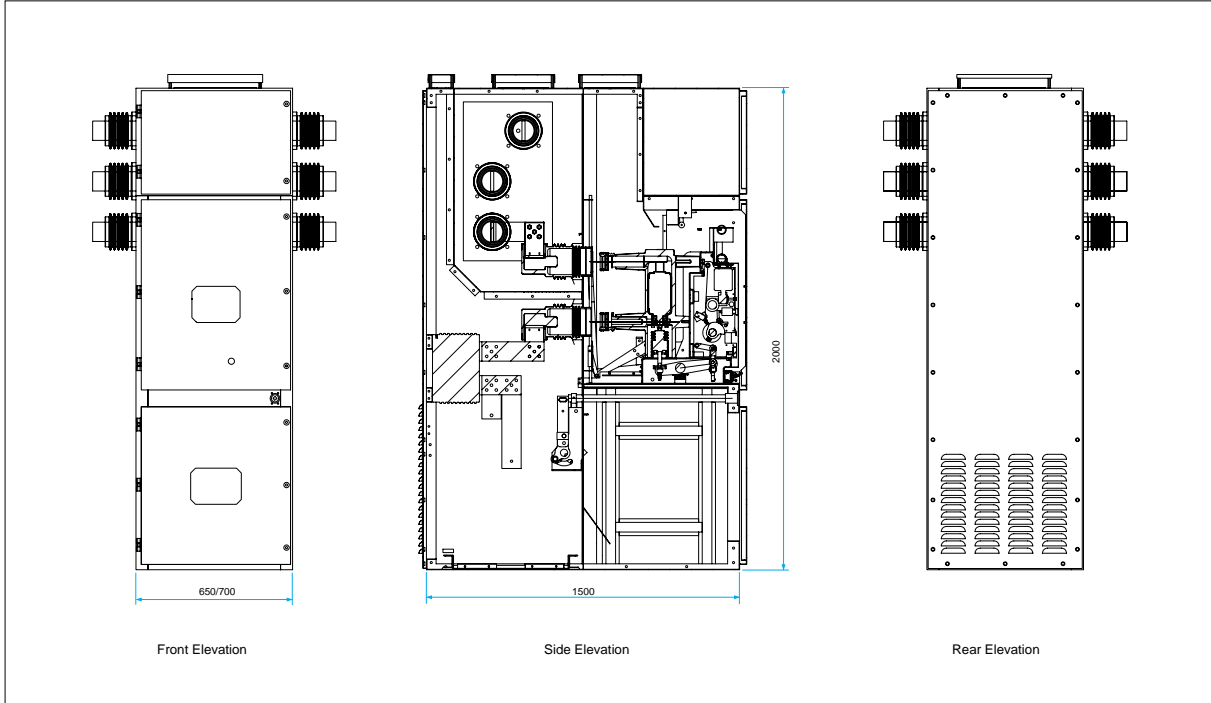





VMS conforms to the following standards and specifications

Construction and design type test, routine test		Metal-enclosed(M) DIN VDE 0670, part 6 IEC 298
Arcing resistance in compliance with		DIN VDE 0670, part 601, IEC 298, Appendix AA Criteria 1-3,6 1s 1-6 1s
Earthing		DIN VDE 0670, part 6 IEC 298, VDE 0141
Operation, control and work near live parts		DIN VDE 0105, part 1
Installation, building dimensions, room height in compliance with		DIN VDE 0101 Closed electrical substations
Protection categories in compliance with*	Basic version To order	DIV VDE 0670, part 6 IP 2X IP 3X / IP 4X
Normal operating conditions		DIN VDE 0670, part 1000 DIN VDE 0670, part 6 IEC 694, IEC 298
Temperature of ambient air	Maximum Mean over 24 hrs Minimum	40 °C 35 °C minus 5 °C indoor (minus 25 °C with additional measures)
Relative humidity Installation altitude		up to 95% up to 1,000m (3,300 ft) above sea level

Enquiries must be made regarding other operating conditions, e.g. higher ambient temperature, different altitude

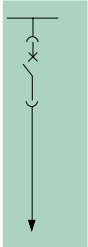
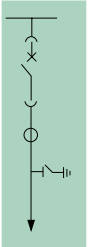
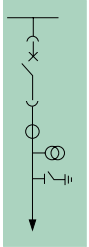
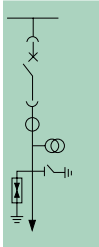
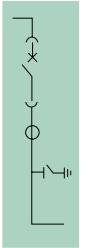
*Up to IP52 to order-where no louvres possible

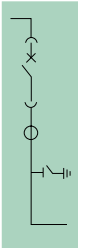
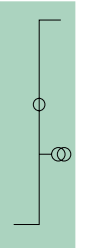
Layout of standard panels

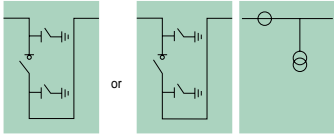
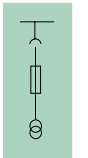
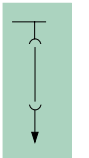
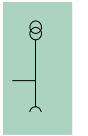
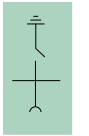
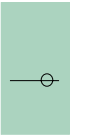
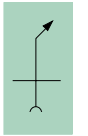
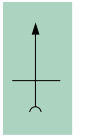
<p>Circuit-breaker panel</p>	<div style="display: flex; justify-content: space-around; align-items: flex-start;"> <div style="text-align: center;">  <p>VECTOR-M/S Vacuum circuit breaker</p> </div> <div style="text-align: center;">  <p>With: Up to 3 current transformers Earthing switch,make-resistant</p> </div> <div style="text-align: center;"> <p>or</p>  <p>With: Up to 3 current transformers Up to 3 voltage transformers Earthing switch,make-resistant</p> </div> <div style="text-align: center;"> <p>or</p>  <p>With: Up to 3 current transformers Up to 3 voltage transformers Surge diverter Earthing switch,make-resistant</p> </div> </div>
<p>Section isolation panel</p>	<div style="display: flex; justify-content: space-around; align-items: flex-start;"> <div style="text-align: center;">   <p>Panel 1 Vacuum Circuit-breaker Up to 3 current transformers Earthing switch,make-resistant</p> <p>Panel 2 Isolator chassis</p> </div> <div style="text-align: center;">     <p>Panel 1 Circuit-breaker or Switch-disconnector Up to 3 current transformers Earthing switch,make-resistant</p> <p>Panel 2 Up to 3 current transformers Up to 3 voltage transformers or Upward feeder panel or Disconnection truck</p> </div> <div style="text-align: center;">  <p>Section isolation with switch-disconnector -up to 1250A - Earthing switch,make-resistant</p> <p>Panel 1 Section isolation with switch-disconnector Earthing switch,make-resistant Panel 2(also supplied 600mm wide) Busbar measurement</p> </div> </div>
<p>truck panel/chassis panel</p>	<div style="display: flex; justify-content: space-around; align-items: flex-start;"> <div style="text-align: center;">  <p>Instrument truck panel/ Instrument chassis panel Without/with fuse-carrier Up to 3 voltage transformers</p> </div> <div style="text-align: center;">  <p>Disconnection truck panel/Dis- connection chassis panel</p> </div> </div>
<p>Busbar</p>	<div style="display: flex; justify-content: space-around; align-items: flex-start;"> <div style="text-align: center;">  <p>Up to 3 single-pole insulated voltage transformers or Up to 2 two-pole insulated voltage transformers</p> </div> <div style="text-align: center;">  <p>Earthing switch, make-resistant</p> </div> <div style="text-align: center;">  <p>Up to 3 current transformers</p> </div> <div style="text-align: center;">  <p>Busbar connection (fully insulated busbar and flat copper connection)</p> </div> <div style="text-align: center;">  <p>Cable connection Up to 2 cable end boxes per phase</p> </div> </div>